



# DOSYMIX® DOSTAM

- *In-line dynamic and static mixers*
- *for any process producing a uniform finished or semi-finished product*
- *suitable for liquid or viscous fluids, thick or fragile ingredients that may swell or contain pieces.*



**DOSTAM**  
static  
mixers



**DOSYMIX®**  
dynamic  
mixers



# DOSYMIX® dynamic mixer



## DOSYMIX® operating principle

Mixing made by simultaneous forward and counter-current mixing.

## DOSYMIX® range of dynamic mixers

The 5 models in our DOSYMIX range are sized for different average capacities. The entire range can handle average product mixing rates from 200 litres/hour to 8,000 litres/hour.

## DOSYMIX® technical specifications and advantages

- Hygienic design → **Cleaning in place**
- Low internal volume → **Limited product loss**
- Attachment of the body by tri-clamp connection → **Quick disassembly**
- Special screw profiles → **Produces a uniform mixture without shear which preserves the product's texture and the flow of pieces.**

### Standard DOSYMIX® model

**Finish:** electro-polished

**Mobile:** Rectangular screw sections

**Connections:** male SMS

**Geared motor powered:** 220-380 V - 50 HZ three phase – IP55 – Class F with stainless steel cover

**Mechanical seal:** Double mechanical seal with hydraulic barrier

**Seals:** Viton and EPDM

**Construction:** 316 L stainless steel without retention areas

Characteristics					Connections			Dimensions (mm)																					
Models	Internal volume (litre)	Weight (Kg)	Motor power (kw)	Rotational speed (rpm)	SMS	DIN male	Tri Clamp Complete	A	B	C	D	E	F	G	H	I	J	K	L	M	N	O	P	Q	R	S	T	U	V
DM 200	0.60	23	0.25	145	25	25	25	147	101	100	461	477	110	320	8	33	420	310	105	274	88	266	58	410	478	76	76	155	360
DM 1000	3.50	36	0.55	145	51	50	51	365	111	100	695	724	110	320	10	41	445	350	125	274	88	280	66	443	511	100	123	175	400
DM 2000	8.00	50	0.75	145	51	50	51	641	126	100	986	1020	110	320	10	41	445	350	125	274	88	280	66	443	511	130	140	175	400
DM 4000	17.00	81	2.20	145	63	65	63	690	137	130	1101	1141	135	310	10	40	681	390	155	300	85	300	85	660	751	170	188	210	450
DM 8000	23.00	140	4.00	145	76	80	76	738	144	150	1186	1232	160	365	15	45	681	440	190	330	110	368	105	678	755	185	219	240	500

### DOSYMIX® options

Possibility of screw with special profile for transfer of large pieces

Simple mechanical seal

Special seals

Double casing to maintain temperature

Other connections: DIN, TRI-CLAMP

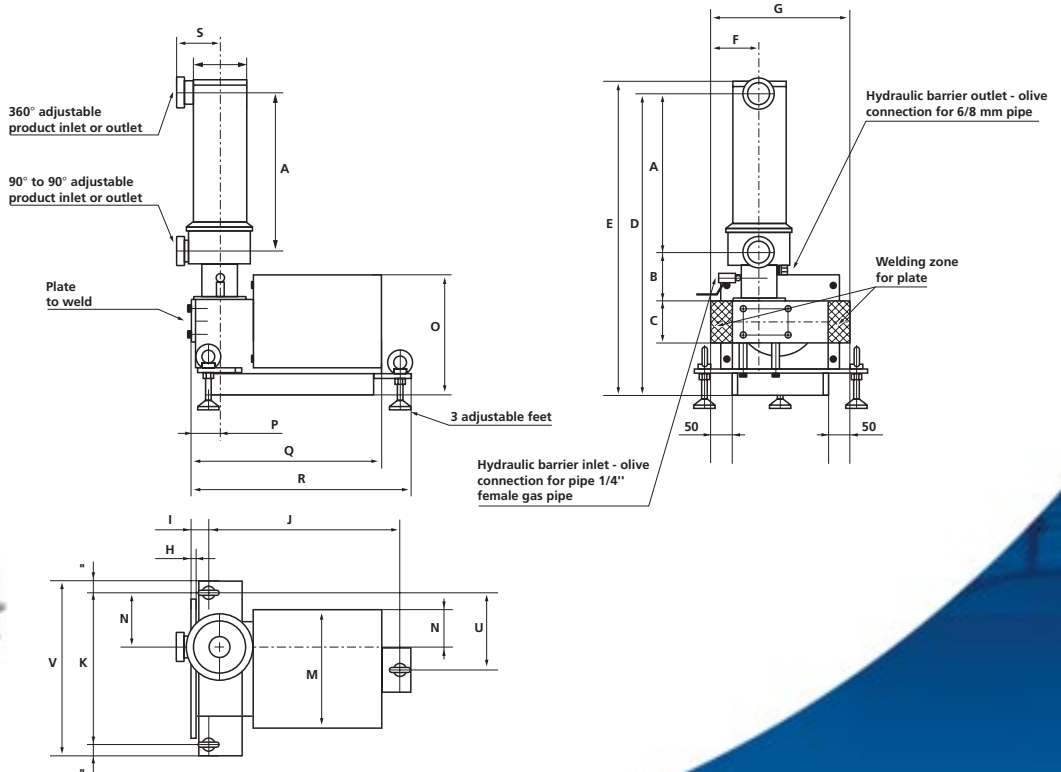
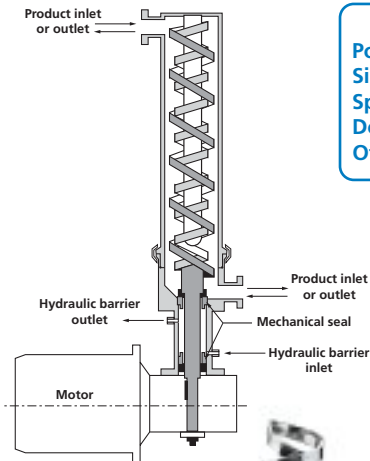

# DOSTAM static mixer

## DOSTAM operating principle

DOSTAM static mixers are composed of a tube containing helical elements mounted alternatively at 90° degree. The breaking up and rotation of the product ensures a uniform mixture when the pumping action is controlled using:

- continuous flowrates, or
- synchronised pulsed flowrates.

## DOSTAM static mixer range

Our range of static mixers includes 5 different diameters sized for different average capacities (from 500 litres/hour up to 30,000 litres/hour).

## DOSTAM technical specifications and advantages

- Simple construction → Easy to integrate in the process (connects to piping)
- Low internal volume → Limited product loss
- No moving parts → No power requirements and no wear
- No spare parts to be replaced → No maintenance

### Standard DOSTAM model

**Finish:** electro-polished

**Connections:** male or female SMS

**Number of elements:** 10

**Seals:** EPDM

**Construction:** 316 L stainless steel without retention areas

Characteristics			Connections				Dimensions (mm)			
Models	Internal volume (litre)	Weight (Kg)	Plain end	SMS	DIN male	Tri Clamp Complete	B	C	E	A*
DS 25-10	0.2	0.8	25	25	25	25	25	23	44	484
DS 38-10	0.7	1.7	38	38	40	38	38	36	67	737
DS 51-10	1.6	3.0	51	51	50	51	51	48.5	86	946
DS 63-10	2.8	5.0	63	63	65	63	63	60.5	103	1133
DS 76-10	5.4	7.5	76	76	80	76	76	72.8	120	1320

\*Total length: A = (number of elements +1) x E

### DOSTAM options

Other tube diameters

Changes in the number of elements

Special seals

Double casing to maintain temperature

Other connections: DIN, TRI-CLAMP

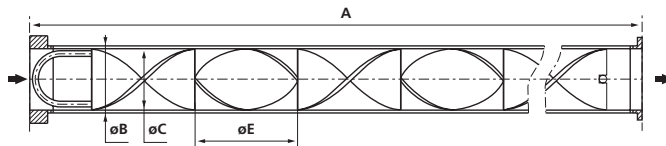



## DOSYMIX® and DOSTAM mixers integrate into industrial process mixing lines.

### ADVANTAGES OF IN-LINE MIXING

Contrary to batch mixing which is performed in batching tanks for discontinuous processes, in-line mixing is perfectly adaptable for continuous processing lines.

The continuous process has the following advantages:

- **Just in time product completion**
- **Reduced waste product**
- **Fast changes in product recipes**
- **Easier inventory management**
- **Minimisation of investments**
- **Reduction in overall size**

### Application examples:

<b>Dairy products</b>	Fruits, pulps, sirops, glucose Ingredients, gels, gum Ferments, rennet Drinking yoghurt	in mixed yoghurt, cream, fromage frais in milk in cheese, kefir in milk and whey from ultrafiltration
<b>Meat, Fish, Petfood</b>	Flavourings, colourings, soda, ingredients	In meat preparation
<b>Confectionary, chocolates</b>	Flavourings, pieces	In chocolat
<b>Convenience foods</b>	Sauces, water, additives Ingredients	In purée, chopped spinach In vegetable soup
<b>Industries</b>	Colourings, resins Soda bisulphite	In varnish In gelatine

**We design solutions adapted to your needs.**

*Don't hesitate to contact our sales engineers who will recommend the best adapted model.*

### Customer references:

3A, Aliment Ultima, Alpina Productos Alimentos, Alpro, Arla Foods, Bright Dairy Chine, Dannon, Danone, Eden Vale, Eurodesserts, Fage, Gloria Pérou, Harry's, Lactalis, Lactogal, Lechera Guadalajara, Lu, Mevgal, MD Foods, National Foods, Nestlé, New Zealand Milk, Parmalat, Pasquier, Senoble, Sigma alimentos, Triballat, Yili Chine, Yoplait ...



**PCM POMPES**  
17 rue Ernest Laval  
BP 35  
92173 VANVES CEDEX  
FRANCE  
Tél. : + 33 (0)1 41 08 15 15  
Fax : + 33 (0)1 41 08 15 00

e-mail : [pcm@pcmpompes.com](mailto:pcm@pcmpompes.com)  
Site web : [www.pcmpompes.com](http://www.pcmpompes.com)



**PCM DOSYS**  
Z.A. Bel Air  
10 rue Mège Mouriès  
78120 RAMBOUILLET  
Tél. : + 33 (0)1 30 46 50 00  
Fax : + 33 (0)1 30 59 88 02

e-mail : [dosys@pcmpompes.com](mailto:dosys@pcmpompes.com)  
Site web : [www.pcmdosys.com](http://www.pcmdosys.com)