



Viscofeeder®

System for feeding and dosing highly viscous products

Force-feed system offers accurate transfer and dosing of highly viscous products with optimum steady flow and high accuracy for any number of production lines.

- Accurate dosing
- Productivity
- Quality and hygiene



DAIRY



BAKED GOODS



MEAT - FISH & ANIMAL FOODS

Viscofeeder[®]'s principle

- 1 Premix chamber:**
Continuous homogenization of the product without introduction of air.
- 2 Barrel independent of the pump:**
feeding of pumps at controlled pressure.
- 3 Cleaning In Place:**
Gravity drainage of whole installation, cleaning of hidden areas.
- 4 Modular equipment:**
Using one or several positive displacement pumps.

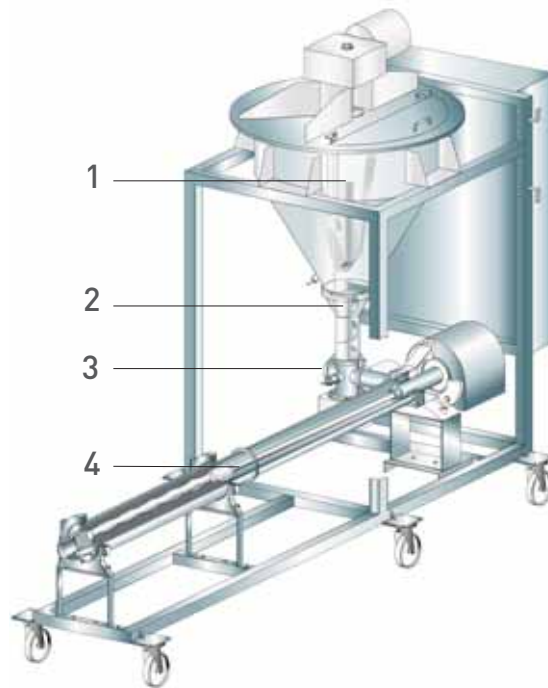

Viscosity > 400 000 cps

Caramel



Key benefits

Versatile: Highly viscous/sticky products up to 10.000.000 cps

Accurate batch or continuous dosing: From 10 ml to several kilos

Productivity: Continuous production with batch loading of product, temperature controlled operation

Quality and hygiene: No air introduction, minimum shearing, Integrated Cleaning In Place



Application examples:

- Transfer of cheese mixtures from kneading trough mixer to the packaging line
- Co-extrusion filling of dry pet-food
- Continuous deposit of dough mix in the desired shape
- Feeding of an extrusion head for biscuit filling
- Dosing and continuous injection of caramel and highly viscous ingredients